



8901 E. PLEASANT VALLEY ROAD
 INDEPENDENCE, OHIO 44131-5508
TELEPHONE: (1) 216-642-1230 • **FAX:** (1) 216-642-6037
E-MAIL: tachs@avtron.com • **WEB:** www.avtronencoders.com

Shaft Grounding Kit Instructions

M585 & M685

INACTIVE DESIGN
 Contact Help Desk

DESCRIPTION

These shaft grounding kits are designed to be installed by customers when used with M585 and M685 pulse generators and are intended for the reduction of bearing problems caused by shaft currents. These kits are also available for other types of Avtron pulse generators.

Under certain operating conditions, a motor shaft can be subject to shaft currents that seek the lowest resistance path to ground. If this path is through bearings, it can shorten bearing life. The shaft grounding option is intended to provide a lower resistance path to divert shaft currents away from bearings.

The shaft grounding kit consists of a gasket sealed brush holder, silver graphite brush, a wire lug and stainless steel mounting hardware. The wire lug is intended to provide a lower resistance ground connection than relying on the mounting hardware.

INSTALLATION

(See accompanying figure 1 on the back of this page.)

1. Install pulse generator as a thru shaft model described in the pulse generator instructions.
2. Position pulse generator so that the face is 1.35" from the end of the 1-1/8" diameter portion of the shaft.
3. Tighten pulse generator onto shaft as described in pulse generator instructions.
4. Install cap. Ensure that cap is flush with end of 1-1/8" diameter section of shaft $\pm 1/16"$. If not properly positioned remove cap and adjust pulse generator position accordingly. Repeat until correct position is achieved. Apply Loctite (10) to screw threads.

CAUTION

If pulse generator is not positioned correctly, damage to grounding brush assembly or pulse generator may occur.

5. Mount the brush holder (1) and gasket (2) to the cap using #8-32 x 1.25 screws (11) and flat washer (12). Apply Loctite (10) to the last 0.25 of screws.
6. Assemble to brush holder the brush (3), screw cap (4), pipe plug (5) and terminal lug (6) using items (7, 8, and 9).
7. A ground wire (6-14 AWG) must be connected to the terminal lug attached to the top of the brush holder. The ground should be connected to a good earth ground, typically the motor frame.

MAINTENANCE

WARNING

All maintenance procedures listed below must be performed by qualified personnel, and with the motor turned OFF to prevent possible injury or death of maintenance personnel.

Inspection

A new brush is 5/8" long. The brush should be replaced after it is worn 3/8" maximum (see Figure 1). The brush should be inspected after 1 year to determine the wear rate for each installation. Replace brush if it is worn to a length of 1/4".

Cleaning

The brush holder cavity should be cleaned every time the brush is removed for inspection. Refer to Figure 1, and clean as follows:

1. Remove the screw cap and brush.
2. Remove the pipe plug from the bottom of the brush holder.
3. Use dry compressed air applied through the brush opening to blow out any worn brush material residue through the bottom of the brush holder. An optional method is to suction the brush residue using a vacuum cleaner.

WARNING

Use safety goggles when using compressed air to prevent possible eye injuries.

No.	Part No.	Qty.	Description
1	C23881	1	Brush holder
2	A24405	1	Gasket
3	410523	1	Brush
4	410522	1	Screw Cap, brush holder
5	416559	1	Pipe Plug
6	367013	1	Terminal Lug
7	509821	1	Screw, Pan Hd, #10-24 X 0.62
8	530073	1	Washer, Flat #10
9	532579	1	Washer, Lock, #10
10	910244	1	Loctite
11	509131	4	Screw, Pan Hd, #8-32 X 1.25
12	530084	4	Washer, Flat #8

FIGURE 1 – Shaft Grounding Kit – Outline Dimensions and Assembly

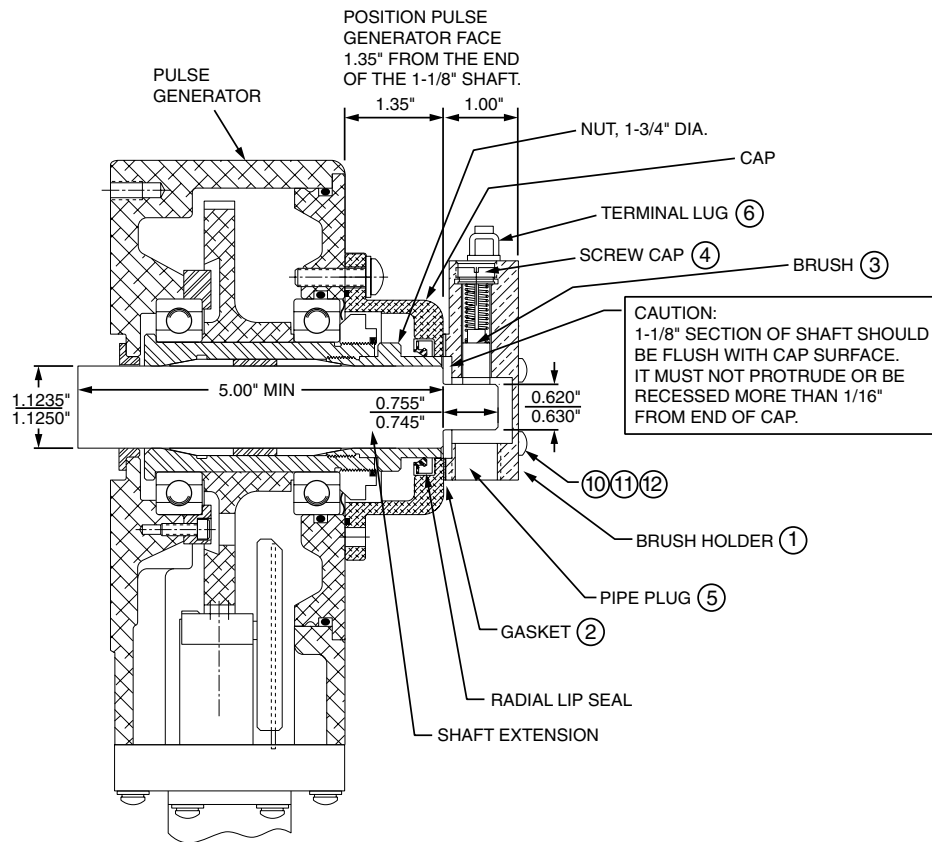
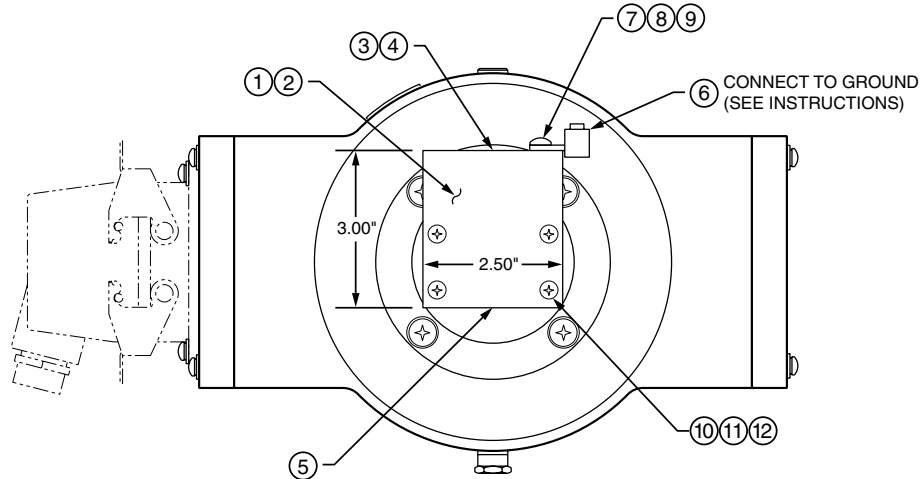

NOTE: This figure is intended to provide general installation information for the shaft grounding kit. The pulse generator shown is Avtron M685.