



8901 E. PLEASANT VALLEY ROAD
 INDEPENDENCE, OHIO 44131-5508
TELEPHONE: (1) 216-642-1230 • **FAX:** (1) 216-642-6037
E-MAIL: tachs@avtron.com • **WEB:** www.avtronencoders.com

Encoder Instructions

M685 SMARTach™
 INACTIVE DESIGN
 Replaced by Model AV685

1 1/8" HOLLOW SHAFT

DESCRIPTION

The Avtron Model M685 SMARTach™ (patents #5,502,376 and #5,545,985) is a **severe duty** incremental encoder (also known as tachometer or rotary pulse generator). Its output is directly proportional to shaft position (pulse count) or speed (pulse rate). The M685 operates down to zero speed and can be used for both control and instrumentation applications.

When mounted to a machine shaft, the M685 design eliminates the need for shaft couplings, adapter flanges, or accessory mounting faces. The unit employs a keyless shaft mount to lock the M685's rotor to a 1.125" diameter shaft. An anti-rotation arm prevents housing rotation while allowing for shaft end float.

The M685 utilizes magnetoresistive sensors. This proven technology is ideal for rugged environments since it is immune to many contaminants that cause optical encoders to fail. These factors make the M685 ideal for demanding industries like paper, metals, and chemical processing.

An Avtron M685 SMARTach is equipped with one or two M484 sensor modules. Each module has a two-phase output (A, B) 90° out of phase, with complements (A, B), (A Quad B Output). A marker pulse with complement (Z, Z̄) is available as an option.

Output resolution is determined by the rotor's base PPR (pulses per revolution), times an M484 sensor multiplier. The M484 sensor module can provide: the base PPR, 1/2 the base PPR, or double the base PPR (see table). With two sensor modules, the same encoder can provide two different PPRs from a given rotor at the same time. Only one rotor per M685 is possible. Sensors are not interchangeable between M685 units with different base PPRs.

	AVAILABLE RESOLUTIONS		
	-48 OPTION	-51 OPTION	-60 OPTION
LOW	240	256	300
MEDIUM	480	512	600
HIGH	960	1024	1200

Example: an M685 could use a M484 1024 PPR sensor output on one side for feedback to a drive system, and simultaneously use a M484 256 PPR sensor on the other side for a process computer.

The M484 removable sensor assembly has a diagnostic package that includes Adaptive Electronics and a Fault-Check output. With this package, the SMARTach can maintain itself, and provide an alarm if there is a problem **before** the problem causes unscheduled downtime.

ADAPTIVE ELECTRONICS

A perfect duty cycle consists of a waveform whose "high" and "low" conditions are of the same duration (50%/50%). It is possible over time for the duty cycle to change due to component drift, temperature changes, or mechanical wear. The Adaptive Electronics extend the life of the M685 by constantly monitoring and correcting duty cycle over time.

FAULT-CHECK

If the Adaptive Electronics reach their adjustment limit, the Fault-Check alarm and LED will notify the drive and operator of an impending failure. This output occurs **before** a failure, allowing steps to be taken to replace the unit before it causes unscheduled downtime. Fault-Check annunciation is available as an "alarm" output through the connector or as an optional integral LED.

INSTALLATION

Equipment needed for installation

Supplied:

1. M685 Encoder
2. Anti-Rotation Arm Kit
3. V-Ring Shaft Seal
4. Thread Locker (blue)
5. Synthetic Grease
6. Anti-Seize (copper)

Not Supplied:

- 1-3/4" Clator Nut Wrench (484017)
- 2-1/2" Locking Nut Wrench (484018)
- 7/16" Wrench
- 1/2" Wrench
- Dial Indicator

The hollow shaft M685 design eliminates the potential for bearing and coupling failures from misalignment, however, excessive housing movement (wobble) may cause undesirable vibrations.

M685 PART NUMBERS AND AVAILABLE OPTIONS (including M484 sensors)

Model	Shaft Options**	Base PPR	Left Module				Right Module			
			Marker	Range (PPR)	Connector	Volts	Marker	Range	Connector	Volts
M685	-- Stub	48- 480	Z- Marker	L- Low Range (Base PPR x 1/2)	N- Wire Leads Only	1- 12-15V				
M685L*	T- Thru	51- 512	- None	M- Medium Range (Base PPR x 1)	M- Wire Leads w/ non-conductive adapter	3- 5-18V	M685/M685L: Same Code Format as Left Module M484/M484L: Not Applicable			
M484	G- Shaft Ground	60- 600		H- High Range (Base PPR x 2)	C- 10 Pin MS w/ Plug D- MS w/ 5' Flex. Cable L- 10 Pin MS Elbow w/ Plug T- Terminal Box S- Terminal Box w/ non-conductive adapter P- Plug-in Industrial G- Plug-in Industrial (Northstar pinout) V- Plug-in Industrial w/ non-conductive adapter	5- 5-24V				

* M685L/M484L - Integral LED Alarm Indicator.

** Thru and Shaft Ground not applicable on M484/M484L. Refer to separate instructions for additional information on the shaft grounding option.

The removable sensor assemblies included with Model M685 Encoders are identified by model number M484. A sensor assembly

consists of a sensor module and a connector option.

The higher the RPM, the more severe the vibration will be from housing movement. In a typical installation a housing movement of 0.007" TIR or less (as measured at the outside diameter of the main encoder body) will not have an adverse effect.

MACHINE SHAFT PREPARATION

Preparing the machine shaft prior to encoder installation is essential in providing an adequate barrier against environmental contamination. In some cases, a separate stub shaft (1.125" D x 4.5" long) will be installed on the motor. To prepare the machine shaft that the M685 is to be installed on, conduct the following procedures (see figures):

- 1) Remove from the M685 the four 1/4-20 UNC machine screws which hold the end cap on the cover plate.
- 2) Remove the end cap, O-Ring, and wave spring, noting the location of each to assist in re-assembly.

ELECTRICAL SPECIFICATIONS

		LINE DRIVER/VOLTAGE INPUT OPTIONS		
		1	3	5
INPUT VOLTAGE (+V)		11.5 - 15.5V	4.8 - 18V	4.8 - 26V
LINE DRIVER		4428	4428	7272
START-UP CURRENT NO LOAD		80mA	300mA	300mA
OPERATING CURRENT NO LOAD		80mA	235mA@5V 90mA@12V	235mA@5V 90mA@12V 60mA@24V
DIFFERENTIAL SQUARE WAVE OUTPUT A leads B for CW rotation, anti drive end view	V _{OH}	((+V)-1.8V) min. @50mA avg.	((+V) -1V) min. @50mA avg.	((+V) -2.3V) typ. @20mA avg.
	I _{OH} (Source)	80mA avg. max., 1.5A peak		80mA avg. max.
	V _{OL}	0.6V max. @5V, 0.4V max. @12V @50mA avg.		0.5V max. @20mA avg.
	I _{OL} (Sink)	80mA avg. max., 1.5A peak		80mA avg. max.
MAXIMUM CABLE DRIVE (feet)		2000		1000@5V in. 500@12V in. 200@24V in.
PROTECTION	Reverse Voltage	Yes		Yes
	Transient	Yes		Yes
	Short Circuit	No		Yes
MARKER		Once per revolution. Pulse width approx. 1/3 of base PPR period.		
ALARM Refer to Engineering Note 30	+V (OUT) 50mA max.	This is a convenience output, internally jumpered to +V operating voltage. It is intended for alarm circuits like solid state relays that can be referenced to +V. *		
	ALARM	Open collector, sink 100mA max, withstand 50V max from common. Output goes low on alarm. *		
	LED	INTEGRAL LED INDICATOR GREEN - Power On RED - Alarm On		

* (Not available on wiring option "G", Northstar compatible pinout.)

MECHANICAL SPECIFICATIONS

SPEED RANGE	0-4500 RPM for base PPR of 480
SPEED RANGE	0-4200 RPM for base PPR of 512
SPEED RANGE	0-3600 RPM for base PPR of 600
WEIGHT	14 lbs.

ENVIRONMENTAL SPECIFICATIONS

OPERATING TEMPERATURE	-20°C to 71°C
DUST AND WATER	A standard M685 encoder is shipped with a universal breather/drain to equalize pressure if the M685 is exposed to temperature cycles and provide a drain for condensate. The labyrinth design limits the entry of dust and water spray. In environments with stable temperatures, the breather may be replaced with a 1/4" pipe plug making the encoder water-tight and dust-tight.

Features and specifications subject to change without notice.

CAUTION

SPANNER WRENCHES MUST BE USED DURING THE FOLLOWING PROCEDURES. Using a substitute can distort the 1-3/4" nut and damage the unit. Do not try to remove the 2-1/2" bearing locknut at any time. This locknut is factory adjusted for optimum M685 performance.

NOTE

Two spanner wrenches, which are **required** for M685 installation, accommodate the 1-3/4" and 2-1/2" nuts found under the cap.

- 3) Holding the 2-1/2" bearing locknut, remove the 1-3/4" dia. clamping nut and slide out the internal compression sleeve.
- 4) Verify that the compression sleeve can be installed by hand on the shaft where the unit is to be installed. File any burrs that obstruct sleeve installation and lightly oil the shaft.
- 5) If a keyway or flat exists on the shaft, provide a sealing medium, or true the shaft back to round using metal putty or equal.
- 6) Return the compression sleeve to the M685 hub.
- 7) Thread the 1-3/4" clamping nut onto the M685 by hand until resistance is felt. **DO NOT TIGHTEN** at this time.

ENCODER INSTALLATION

Installing the M685 and Anti-Rotation Arm:

1) The free end of the anti-rotation arm must be secured by the customer to a stationary member such as the floor or machine frame. Refer to "Anti-Rotation Arm Mounting Guidelines" on the last page for general requirements.

2) Based on the location of the stationary point and the guidelines on page 4, attach the 1/4" thick mounting board to one of two places on the M685. Use two 1/4-20 UNC by 3/4" long machine screws provided.

3) Apply anti-seize to machine shaft. A packet of silicone grease is provided to lubricate the following shaft seals: First, **ALL** M685 types have an O-Ring inside their hollow shafts at the motor end. In addition, in **THRU-SHAFT** types, the clamping nut has an O-Ring on the inside, plus the outside of the clamping nut requires lubrication for the radial lip seal per step 8b. Slide the M685 onto the machine shaft, mounting the board first. Ideally, the M685 housing will be 1/2" to 1" from the motor or machine housing, but this may vary depending on the machine profile and the anti-rotation arm clearance requirements. Consider shaft end float when positioning the M685.

4a) FOR **STUB SHAFT** APPLICATIONS, place the M685 3-1/4" to 4" onto the shaft. The end of the machine shaft must extend completely through the M685 compression sleeve and be approximately flush with the end of the 1-3/4" clamping nut.

4b) FOR **THRU SHAFT** APPLICATIONS, position the M685 as required.

5) Attach free end of the anti-rotation arm to the 1/4" mounting board using the shoulder bolt provided.

6) Remove 1-3/4" clamping nut and apply liquid thread locker to the threads. (Loctite grade 242, supplied, should be used in most applications.)

SHAFT STYLE

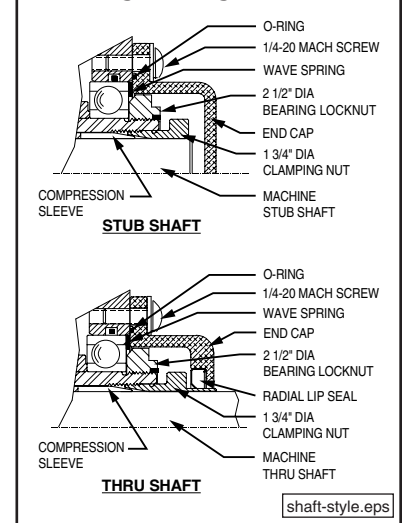

CLAMPING NUT

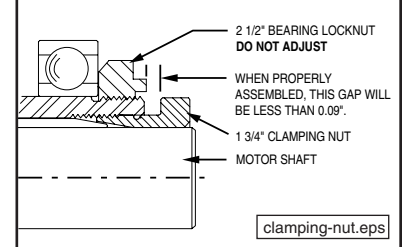

7) Replace 1-3/4" clamping nut and tighten so the gap is less than or equal to 0.09", as shown in **CLAMPING NUT** sketch (approx. 15-20 ft-lbs.), holding the 2-1/2" bearing locknut in place. Spanner wrenches are required for this operation.

8a) FOR **STUB SHAFT INSTALLATIONS**, replace the end cap with the wave spring (loading spring) against the bearing and the O-ring located in the cap groove. Secure the end cap with the four 1/4-20 UNC machine screws previously removed. Apply the thread locker to the screws when assembling.

8b) FOR **THRU SHAFT APPLICATIONS**, prior to replacing the end cap per step 8a, apply a small amount of silicone grease (provided) to the seal surface on the 1-3/4" clamping nut. The radial lip seal in the end cap will seal on this surface.

ENVIRONMENTAL CONSIDERATIONS

Special attention is to be given to conduit runs, interconnection wiring and NEMA type enclosure mounting. In those applications where ambient temperatures are controlled within 20° C and high humidity/washdown are not present, position the flexible conduit with a slight sag to prevent any condensation from entering the encoder via conduit.

In harsh environments, which include temperature extremes, high humidity, equipment washdown or atmosphere contamination, **extra** care is required. Follow these steps to reduce potential problems:

- 1) Always mount connection points, conduit couplings, junction boxes, etc., lower than actual encoder.
- 2) For washdown areas, shroud or otherwise cover the encoder to prevent direct water spray. Do not attach the shroud directly to the encoder.
- 3) Keep conduit outputs and axis of rotation horizontal.

The encoder is shipped standard with a universal breather/drain in the bottom port and a stainless steel pipe plug in the top port. See Environmental specifications. The breather must be at the lowest point of the tach and have a clear, unrestricted drainage path. If some object interferes with the breather, first try to modify that object. If clearance cannot be provided, the breather may be removed, but only if at least one of the following conditions is met:

- 1) The opening is protected from direct contact with standing or splashing liquids.
- 2) If temperatures will be stable (within 20° C), the breather may be replaced with a 1/4" pipe plug.
- 3) If neither of the above is possible, i.e. the opening must be plugged for protection and temperatures will vary, then the unit should be purged with clean, low-pressure, filtered, positive air pressure (<5

psi) through the top opening. Do not remove the top plug except to provide such purging. Purging of the M685 should be reviewed with Avtron.

WIRING INSTRUCTIONS

For bidirectional operation of the 2-phase SMARTach, proper phasing of the two output channels is important. Phase A channel leads Phase B channel for clockwise shaft rotation as viewed from the anti-drive or accessory end of the motor (M685 mounting end).

Wiring option "G" provides a pinout compatible with Northstar encoders, with a cable shield connection on pin 10. Note that this option does not ground the shield; Avtron still recommends grounding the shield at the drive end of the cable for all wiring options.

CORRECTIVE ACTION FOR PHASE REVERSAL

- 1) **Remove Power.**
- 2) Exchange wires on cable, either at encoder cable end, or at speed controller end (but not both).
 - a) **Single Ended 2 Phase Wiring** (see wiring diagram) Exchange A and B at the use end of the wires.
 - b) **Differential 2 Phase Wiring** (see wiring diagram) Exchange **either** A with \bar{A} in the phase A pair **OR** B with \bar{B} in the phase B pair but **NOT** both.
- 3) **Apply Power.**
- 4) Verify encoder feedback is correct, using hand rotation of shaft, or jog mode of the speed controller.

Interconnecting cables specified in the wire selection chart below are based on typical applications. Refer to the system drawing for specific cable requirements where applicable.

Physical properties of cable such as abrasion, temperature, tensile strength, solvents, etc., are dictated by the specific application. General electrical requirements are: stranded copper, 22 thru 16 gauge (Industrial EPIC options can use 14 AWG), each wire pair individually shielded with braid or foil with drain wire, 0.05 uF maximum total mutual or direct capacitance, outer sheath insulator, 1,000 ft. max. See Wire Selection Chart below for some suggested cables.

NOTE

When using the plug-in industrial EPIC connector ("G", "P", "V", "X", or "Z" options), the wire ends must be tinned with solder before connection at the screw terminals.

WIRING DIAGRAMS

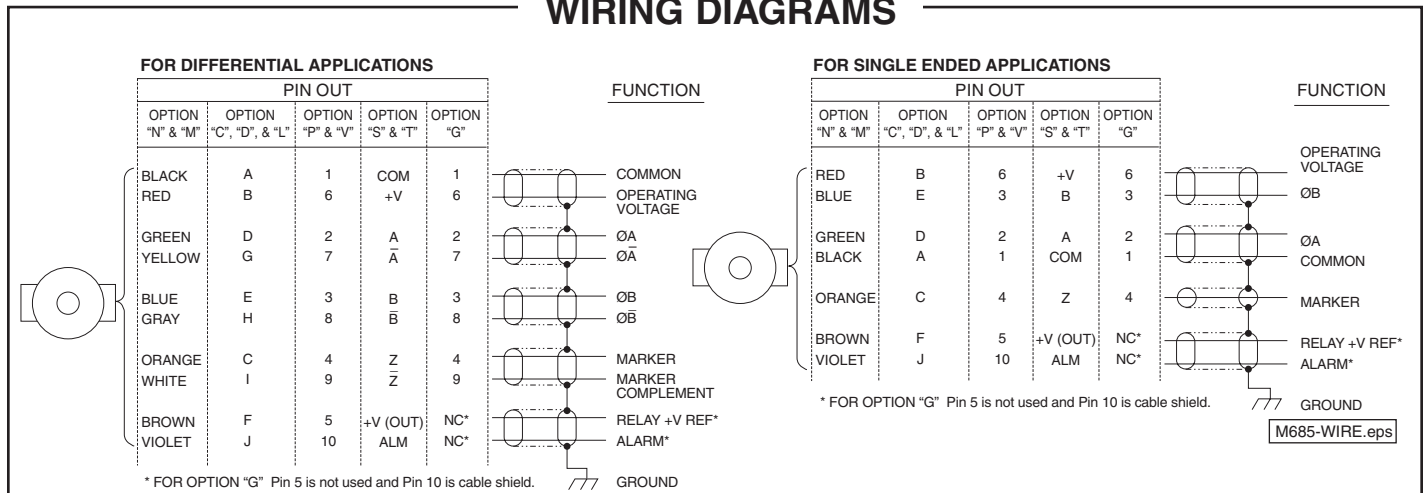

TYPICAL WIRE SELECTION CHART
for 18 AWG, multiple pair, individually shielded

	BELDEN	ALPHA
2 PAIR	9368	6062
3 PAIR	9369	6063
4 PAIR	9388	6064
6 PAIR	9389	6066

wire-chart.eps

Avtron standard warranty applies. Copies available upon request. Specifications subject to change without notice.

M685-WIRE.eps

ANTI-ROTATION ARM MOUNTING GUIDELINES

The anti-rotation arm stabilizes the encoder and keeps it from rotating as the machine shaft rotates. To get the best performance, minimize generator movement by following these anti-rotation arm mounting guidelines as closely as possible.

1. Mount M685 with conduit entry ports positioned horizontally.
2. Fasten the 1/4" thick mounting board to the inboard side of the M685

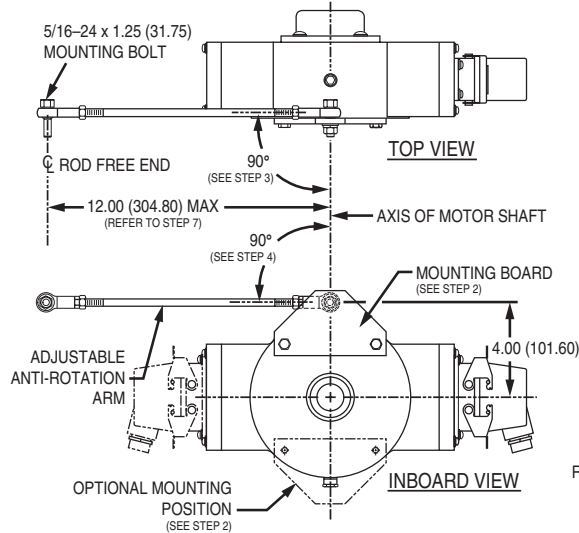

in one of the two positions shown. Use the two 1/4-20 UNC x 3/4" long fasteners.

3. Mount anti-rotation arm perpendicular to motor shaft axis of rotation. Arm mounting bolts and associated rod bearings should be parallel to motor shaft also (top view).
4. Mount anti-rotation arm approx. 90° to a line established between the mounting board mounting hole and shaft centerline (viewed from end).
5. Mount M685 as close as possible to the motor with the mounting board closest to the motor.
6. Establish a stationary (static) mounting point for the free end of the anti-rotation arm, using the guidelines above. Use the bolt provided to fasten arm to stationary point.
7. The anti-rotation arm is fully threaded and can be adjusted in length. The recommended length is 8" to 12".

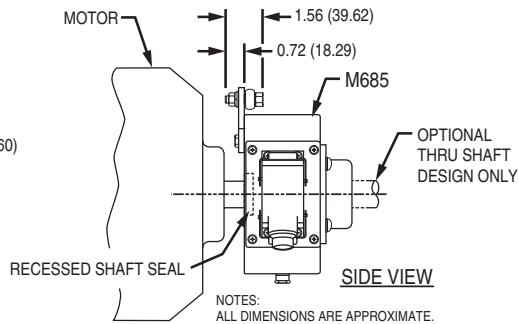

antirotation-arm.eps

OUTLINE DIMENSIONS AND OPTION DETAILS

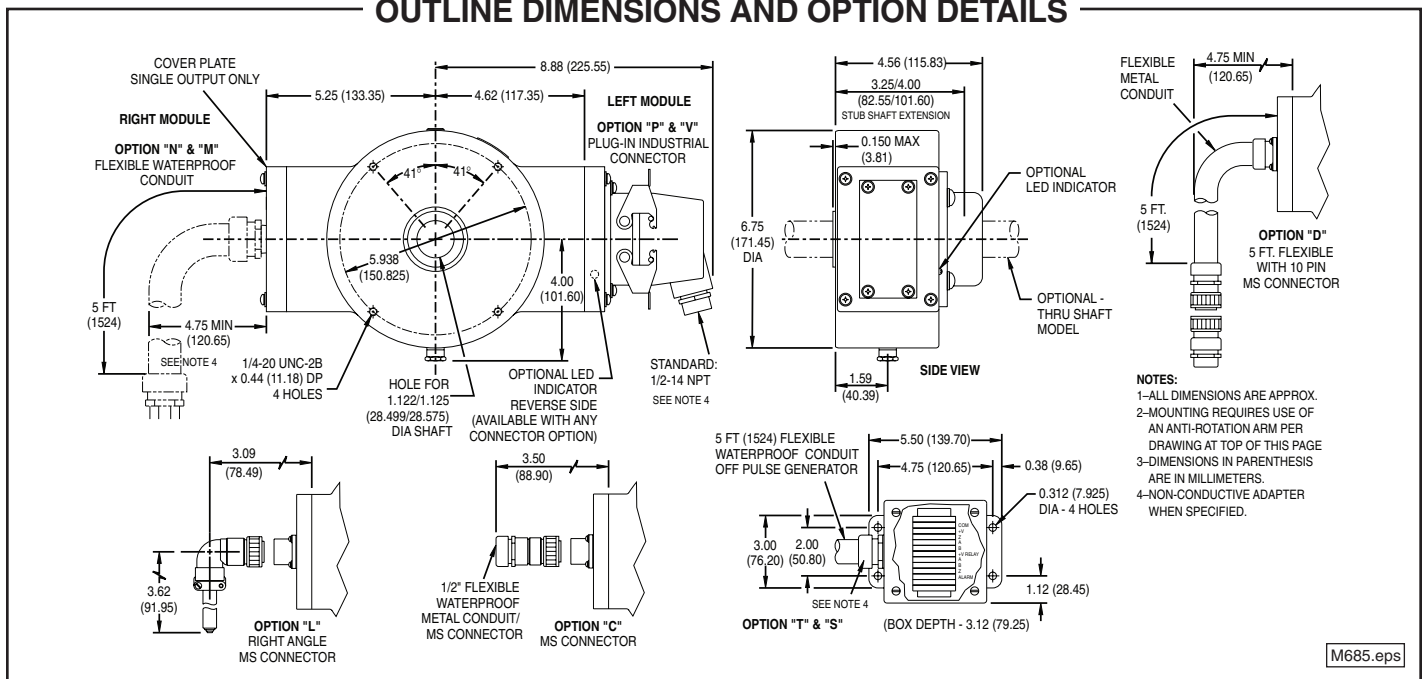

M685.eps

EU Declaration of Conformity: The Model M685 SMARTach Encoder has been assessed and type tested against the following Harmonized European Standards: EN 50081-1:1992, EN 50082-1:1998. The Model M685 has been found to be compliant with the requirements of EU Directive 89/336/EEC provided that the following conditions are met: The electrical supply to the M685 must be within specified limits. The electrical supply must offer suitable protection from voltage surges unless the application does not require such protection. On behalf of Avtron Industrial Automation, Inc.: Stephen L D'Henin, Certification Manager, Epsilon Certification Service.

Features and specifications subject to change without notice. Avtron standard warranty applies. All dimensions are in inches (mm).



8901 E. PLEASANT VALLEY RD., INDEPENDENCE, OH 44131, U.S.A. • (216) 642-1230 • FAX (216) 642-6037 • www.avtronencoders.com



REV: 07-21-06