



8901 E. PLEASANT VALLEY ROAD
 INDEPENDENCE, OHIO 44131-5508
TELEPHONE: (1) 216-642-1230 • **FAX:** (1) 216-642-6037
E-MAIL: tachs@avtron.com • **WEB:** www.avtronencoders.com

Encoder Instructions

M1250 SMARTach™
INACTIVE DESIGN
 Replaced by Model AV125

12 1/2" FC FACE MOUNT MODULAR

This M1250 encoder specification sheet includes partial installation information. For complete installation and maintenance information refer to the M1250 instruction manual.

DESCRIPTION

The Avtron Model M1250 SMARTach™ (patents #5,502,376, #5,608,277 and #5,545,985) is an incremental encoder (also known as a tachometer or rotary pulse generator), allowing operation down to zero RPM. It provides a specific number of electrical Pulses Per Revolution (PPR) that are proportional to a shaft's revolution. The M1250 SMARTach™ is a bearingless, couplingless, modular design, providing unequaled reliability and mechanical performance.

The M1250 is compatible with mounting on motors with a 12.5" accessory flange. Both end-of-shaft and through shaft mountings are accommodated.

The M1250 encoder consists of three parts: a rotor, a stator housing, and removable sensor module. These precision machined parts mount to the accessory end of a motor that conforms to 1987 NEMA MG 1-11.68 for Type FC Face Mounting. After mounting, a simple, no-measurement gapping sequence precisely sets the sensor-rotor gap to factory specifications.

An Avtron SMARTach™ can be equipped with one or two sensor modules. Each module has a two-phase output (A, B) 90° out of phase, with complements (Ā, B̄), (A Quad B Output). A marker pulse with complement (Z, Z̄) is available as an option.

Output resolution is determined by the rotor's base PPR (pulses per revolution), times an M1284 sensor multiplier. The M1284 sensor module can provide: the base PPR, 1/2 the base PPR, or

double the base PPR (see table). With two sensor modules, the same encoder can provide two different PPRs from a given rotor at the same time.

Example: an M1250 could use a M1284 1200 PPR sensor output on one side for feedback to a drive system, and simultaneously use a M1284 300 PPR sensor on the other side for a process computer.

The M1284 removable sensor assembly has a diagnostic package that includes Adaptive Electronics and a Fault-Check output. With this package, the SMARTach™ can maintain itself, and provide an alarm if there is a problem **before** the problem causes unscheduled downtime.

ADAPTIVE ELECTRONICS

A perfect duty cycle consists of a waveform whose "high" and "low" conditions are of the same duration (50%/50%).

Most modular encoders similar to the M1250 have their electrical parameters (duty cycle and transition separation) determined by factory settings under nominal conditions for sensor gap and rotor axial position, which rarely match the actual installed conditions. It is possible over time for the duty cycle to change due to component drift, temperature changes, or mechanical wear. The Adaptive Electronics extend the life of the M1250 by continuously monitoring and correcting duty cycle over time.

FAULT-CHECK

If the Adaptive Electronics reach their adjustment limit, the Fault-Check alarm and LED will notify the drive and operator of an impending failure. This output occurs **before** a failure, allowing steps to be taken to replace the unit before it causes unscheduled downtime. Fault-Check annunciation is available as an "alarm" output through the connector or as an optional integral LED.

		AVAILABLE RESOLUTIONS
		-60 OPTION
LOW		300
MEDIUM		600
HIGH		1200

M1250 PART NUMBERS AND AVAILABLE OPTIONS (including M284 sensors)

Model	Base PPR	Left Module				Right Module			
		Marker	Range (PPR)	Connector	Volts	Marker	Range	Connector	Volts
M1250 M1250L* M1284 M1284L*	60- 600	Z- Marker - None	L- Low Range (Base PPR x 1/2) M- Medium Range (Base PPR x 1) H- High Range (Base PPR x 2)	N- Wire Leads Only C- 10 Pin MS w/ Plug L- 10 Pin MS Elbow w/ Plug R- Small MS Bulk Head T- Terminal Box K- Condulet P- Plug-in Industrial G- Plug-in Industrial (Northstar pinout) Z- Plug-in Industrial 3' Flex. Cable	1- 12-15V 3- 5-18V 5- 5-24V	M1250/M1250L: Same Code Format as Left Module M1284/M1284L: Not Applicable			
* M1250L/M1284L - Integral LED Alarm Indicator									

The removable sensor assemblies included with Model M1250 Encoders are identified by model number M1284. A sensor assembly consists of a sensor module and a connector option.

Separate shaft grounding kits are available for 0.400" end-of-shaft applications.

THROUGH SHAFT APPLICATIONS	
ROTOR PART NUMBERS	
SHAFT SIZE*	600 PPR
0.6250/0.6245	B29207-1
1.0000/0.9995	B29207-2
1.1250/1.1245	B29207-3
1.3750/1.3745	B29207-4
1.6250/1.6245	B29207-5
1.8750/1.8745	B29207-6
2.0000/1.9995	B29207-7
2.1250/2.1245	B29207-8
2.2500/2.2495	B29207-9
2.3750/2.3745	B29207-10
2.5000/2.4995	B29207-11
2.8750/2.8745	B29207-12
3.3750/3.3740	B29207-13
3.8750/3.8740	B29207-14
4.3750/4.3740	B29207-15
4.8750/4.8740	B29207-16

*The M1250 can accommodate motor shafts which pass through the rotor and range in size from 5/8" to 4-7/8".

BUILT-IN SPARE

The design of the M1250 uses a special sensor module. In applications where 600 PPR or below is used, the M1250 automatically switches to a second set of sensor elements if a problem occurs in the primary set. The drive or controller is notified by the Fault-Check system.

INSTALLATION

Equipment needed for installation

Supplied:

- | | |
|--------------------------------|----------------------|
| 1. M1250 Encoder | 3. Hex Hd. Cap Screw |
| 2. Washer, Spring Lock 5/8 (4) | 5/8-11 x 4.00 (4) |

Rotor

1. Rotor Installation Hardware Kit
2. Anti-Seize Compound (copper)
3. Thread Locker (blue)

Not Supplied:

- 5/16" Wrench
- 5/64" Hex Wrench
- Phillips Screwdriver
- Dial Indicator
- Vernier Caliper
- 7/16" Nut Driver

Optional:

- Rotor Gauge Block

Refer to the back page of these specifications for outline and mounting dimensions. The motor must comply with 1987 NEMA MG1-11.68 for dimensions, face runout and shaft runout. Axial float or endplay must be less than ± 0.050 inch.

ROTOR INSTALLATION

Apply anti-seize compound to the shaft. Position the rotor on the shaft and tighten with the hardware indicated above, using a thread locker such as Loctite 222 or 242 (supplied with installation kits).

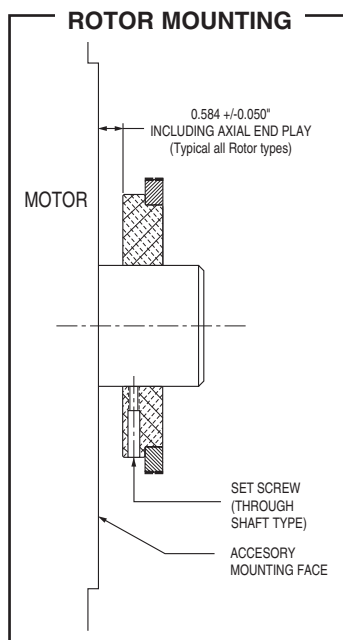

THROUGH SHAFT APPLICATIONS: The through-shaft must project at least 1.5" from the motor face. If it is greater than 2.7" long, the cover plate cannot be used – in those cases, order the through shaft seal kits. Slide the rotor on the shaft with the set screw hub nearer the motor face. The rotor centerline must match the sensor centerline. To accomplish this, the space between the mounting face and the side of the rotor must be set to 0.584", as shown in the figure. This dimension must be held within ± 0.050 " including axial endplay.

STATOR HOUSING INSTALLATION

The stator housing is retained to the motor using four, 5/8-11 x 4.00 inch bolts, flat washers, and spring type lock washers. See tables for installation hardware kit part numbers, available separately. If the stator is to be sandwich mounted between an accessory such as a fan and the motor, select the bolt length accordingly. Carefully move the stator housing and sensor assembly into position, avoiding contact with the rotor. **AVOID SEVERE BUMPS** to the sensor assembly. Install the four mounting bolts (torque 50 to 60 foot pounds).

CAUTION

DO NOT use silicone sealants or caulk of any kind on the motor or encoder face; these can cause misalignment or sensor scraping damage. The M285 electronics are fully sealed; water may enter and leave the rotor area as needed. A drain hole option is available if frequent moisture buildup is expected.

SENSOR ASSEMBLY INSTALLATION

Before an M1284 sensor assembly is installed in a stator housing, it must be in the retracted position (as shipped). If the sensor was previously used and the sensor-rotor gap set, then it is not retracted and the READJUSTMENT SEQUENCE, given in the Maintenance section of the M285 instruction manual, must first be done. Always do the readjustment sequence if there is any question.

1. Insure that mating surfaces are clean and free of paint, burrs, etc.
2. Carefully position the sensor assembly in the stator housing, using the rounded corner of the mounting surface to correctly orient the sensor. Use CAUTION not to damage sensor face. The rotor **MUST** be stationary for this procedure.
3. Install the four #8-32 x 1.25" mounting screws, flat washers and lock washers provided. If the stator housing and rotor have been mounted, the sensor-rotor gap may now be set by following the GAPPING SEQUENCE which follows.

SENSOR-ROTOR GAP SETTING

Although the M1250 is quite tolerant of gap variations, a sensor operating at the optimum gap naturally offers optimum performance and reliability, since the unit will better tolerate normal wear and aging. To provide your M1250 encoder with the optimum gap, its unique design allows a simple, on-site gap adjustment (no measuring required), to be done after installation. The following Gapping Sequence describes this initial adjustment. This procedure can be done once, as presented. If it should be necessary to repeat the gapping sequence, for example after disassembly or service, the sensor must first be reset as described in the Maintenance section of the M285 instruction manual.

GAPPING SEQUENCE

1. Install the rotor, stator and sensor(s) as previously described. The sensor should be retracted (as shipped).

CAUTION

The rotor MUST be stationary for this procedure.

2. See SENSOR ASSEMBLY illustration. Loosen the 1/4-20 lock nut (next to the quick release pin ring) until you see the quick release pin move as the sensor temporarily contacts the rotor. The clamping pin should be free to rotate slightly.

- Retighten the 1/4-20 locknut until snug (approximately 35 in-lbs) but not more than 1/2 turn after locknut contacts housing.
- Pull the ring to remove the quick release pin. The proper gap between the sensor and the rotor has now been established.

CAUTION

Sequence must be followed properly or damage to the sensor and the rotor will result.

ELECTRICAL SPECIFICATIONS

		LINE DRIVER/VOLTAGE INPUT OPTIONS		
		1	3	5
INPUT VOLTAGE (+V)		11.5 - 15.5V	4.8 - 18V	4.8 - 26V
LINE DRIVER		4428	4428	7272
START-UP CURRENT NO LOAD		80mA	300mA	300mA
OPERATING CURRENT NO LOAD		80mA	235mA@5V 90mA@12V	235mA@5V 90mA@12V 60mA@24V
DIFFERENTIAL SQUARE WAVE OUTPUT A leads B for CW rotation, anti drive end view	V _{OH}	((+V)-1.8V) min. @50mA avg.	((+V) -1V) min. @50mA avg.	((+V) -2.3V) typ. @20mA avg.
	I _{OH} (Source)	80mA avg. max., 1.5A peak		80mA avg. max.
	V _{OL}	0.6V max. @5V, 0.4V max. @12V @50mA avg.		0.5V max. @20mA avg.
	I _{OL} (Sink)	80mA avg. max., 1.5A peak		80mA avg. max.
MAXIMUM CABLE DRIVE (feet)		2000		1000@5V in. 500@12V in. 200@24V in.
PROTECTION	Reverse Voltage		Yes	Yes
	Transient		Yes	Yes
	Short Circuit		No	Yes
MARKER		Once per revolution. Pulse width approx. 1/3 of base PPR period.		
ALARM Refer to Engineering Note 30	+V (OUT) 50mA max.	This is a convenience output, internally jumpered to +V operating voltage. It is intended for alarm circuits like solid state relays that can be referenced to +V. *		
	ALARM	Open collector, sink 100mA max, withstand 50V max from common. Output goes low on alarm. *		
	LED	INTEGRAL LED INDICATOR GREEN - Power On RED - Alarm On		

* (Not available on wiring option "G", Northstar compatible pinout.)

MECHANICAL SPECIFICATIONS

SPEED RANGE	0-3600 RPM for base PPR of 600
OPERATING TEMPERATURE	-20°C to 80°C
MOUNTING REQUIREMENTS	12.5" pilot per NEMA MG 1-11.68 type FC accessory mounting face. Tolerance are: Rotor runout: 0.006" FIM (Full Indicator Movement) Pilot eccentricity: 0.040" FIM Shaft axial end play: ± 0.050"
WEIGHT	12 lbs.

Features and specifications subject to change without notice.

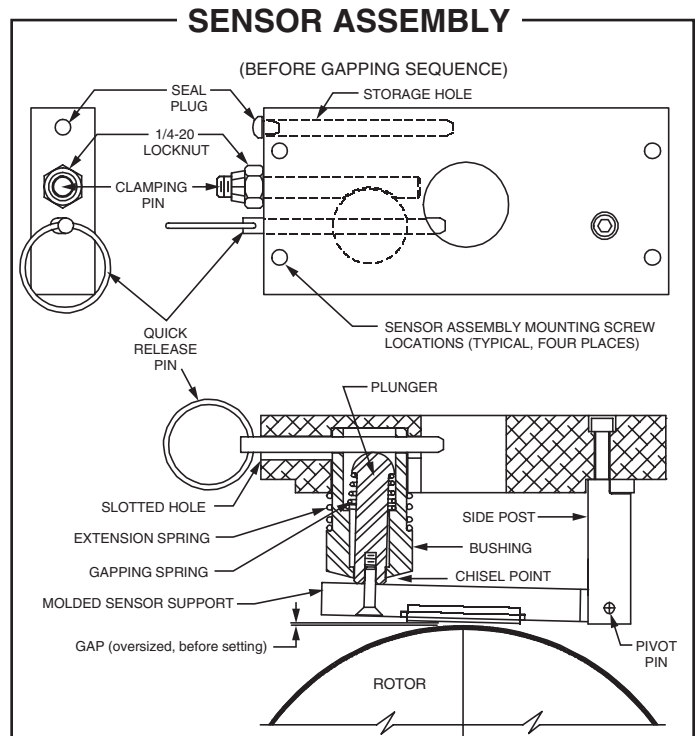

WIRING DIAGRAMS

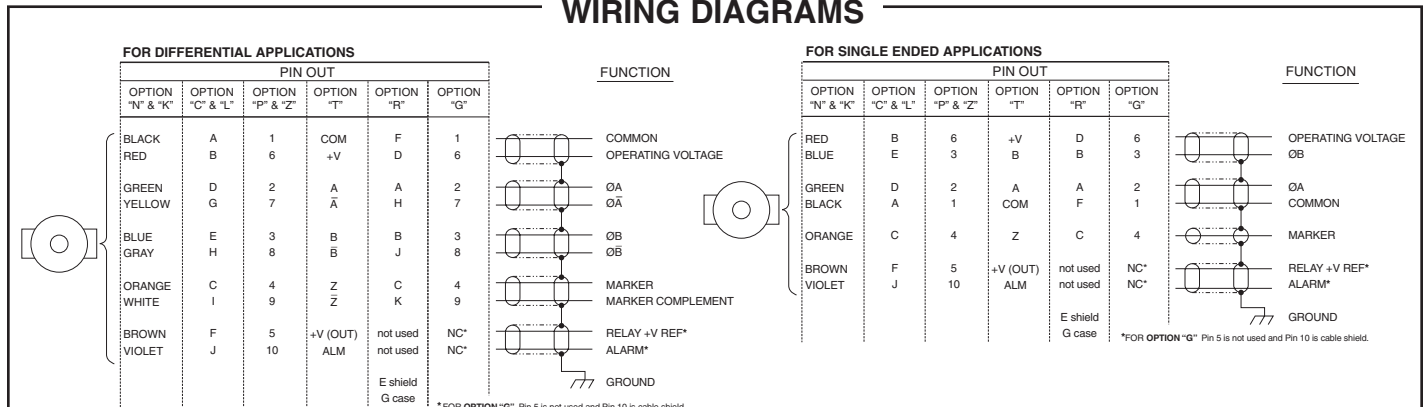

TYPICAL WIRE SELECTION CHART for 18 AWG, multiple pair, individually shielded

	BELDEN	ALPHA
2 PAIR	9368	6062
3 PAIR	9369	6063
4 PAIR	9388	6064
6 PAIR	9389	6066

NOTE: When using the plug-in industrial connector ("G", "P", "V", "X", or "Z" options), the wire ends must be tinned with solder before connection at the screw terminals.

Avtron standard warranty applies. Copies available upon request. Specifications subject to change without notice.

5. A round storage hole, located next to the 1/4-20 locknut, contains a seal plug. Move the seal plug (P/N 469117) to the slotted hole that held the quick release pin, and place the pin in the storage hole. DO NOT REINSERT THE PIN IN THE SLOTTED HOLE.

MAINTENANCE

For instructions on stator removal, rotor removal, and sensor re-adjustment, see the maintenance section of the M285 instruction manual.

OUTLINE DIMENSIONS AND OPTION DETAILS

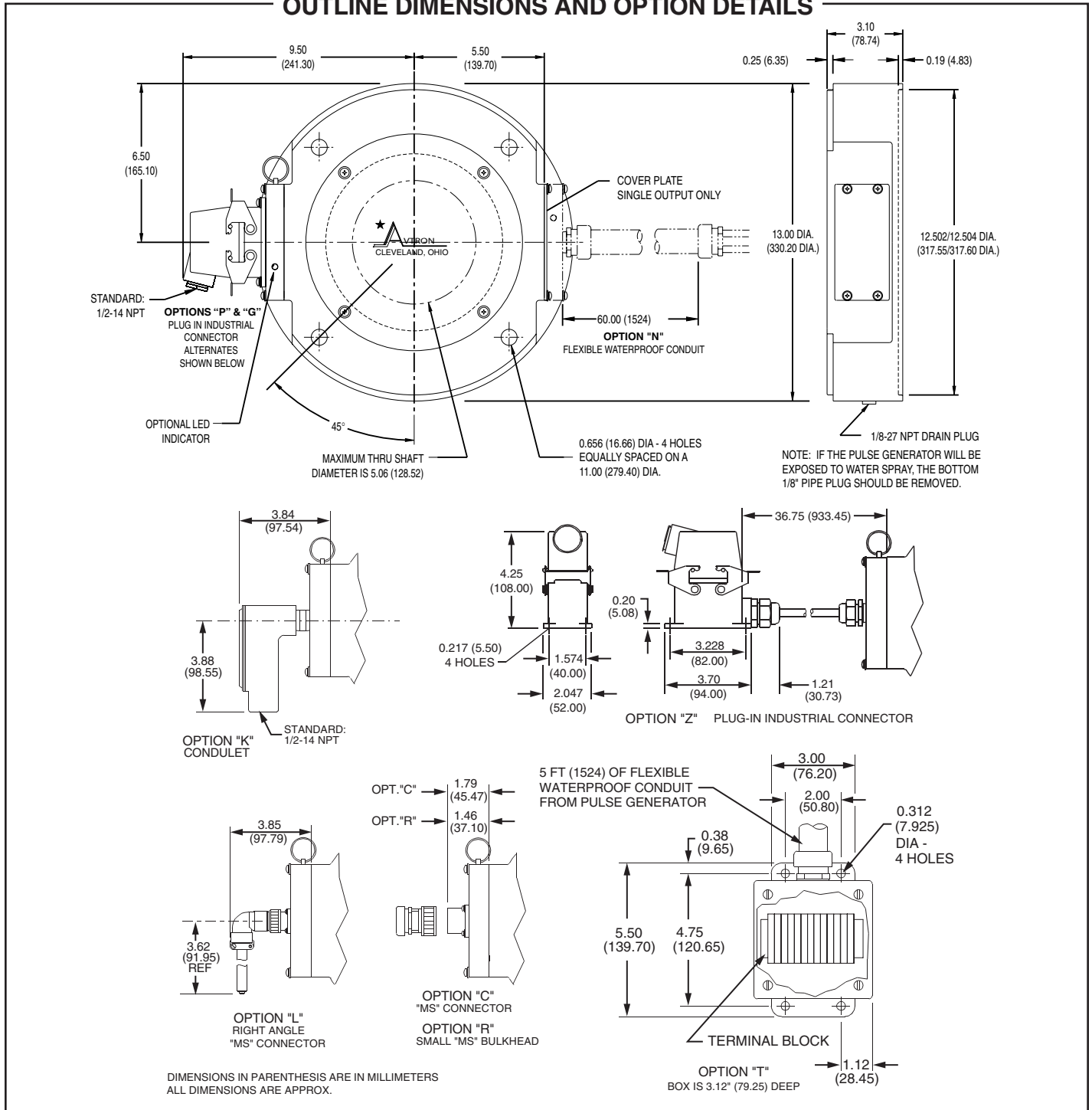

Features and specifications subject to change without notice. Avtron standard warranty applies. All dimensions are in inches.



8901 E. PLEASANT VALLEY RD., INDEPENDENCE, OH 44131, U.S.A. • (216) 642-1230 • FAX (216) 642-6037 • www.avtronencoders.com

REV: 07-21-06