



8901 E. PLEASANT VALLEY ROAD  
 INDEPENDENCE, OHIO 44131-5508  
**TELEPHONE:** (1) 216-642-1230 • **FAX:** (1) 216-642-6037  
**E-MAIL:** tachs@avtron.com • **WEB:** www.avtronencoders.com

# Brushless Tachometer Instructions

## K661

Frequency to Voltage Converter

### DESCRIPTION

The K661 is a high voltage frequency to DC converter. The unit is designed for use in conjunction with encoders and pulse generators as a direct replacement of analog tachometer generators such as the G.E. types BC46 and BC42, A.E.I. type BD2510 and Reliance type RE210 in existing drive control systems. The unit precisely converts an input frequency representing the process variable (speed) to an accurate, stable, analog DC voltage for control use.

#### K661 Output with Avtron M-series Encoders and Pulse Generators

Three styles of encoders are recommended for use with the K661. All maintain NEMA 56-C face dimensions to permit direct replacement of analog tachs. Each may also be foot mounted. Encoder selection depends on the output required from the K661 and types of service required.

#### NOTE

**For Avtron SMARTachs (M285, M485, M685, M1250) use only Output Option 1 (12-15 VDC Line Driver). K661 can supply 100 mA max. current to the encoder.**

#### For example:

**STYLE 1:** Two Phase Zero Speed (Example Encoder: M485)

For bidirectional, zero speed applications. The K661 output voltage reverses when drive runs backwards. Use with nearly any drive.

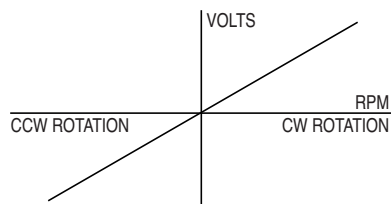

**STYLE 2:** Single Phase Zero Speed (Example Encoder: M485)

For unidirectional, zero speed applications. The K661 output voltage does not reverse when drive runs backwards. 3 wire interconnection to K661. Use with non-regenerative drives or drives where tach voltage does not determine rotation direction.

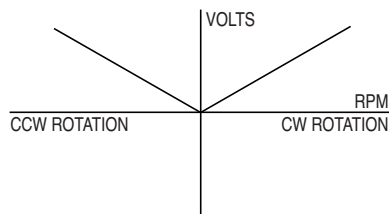

**STYLE 3:** Reluctance (Example Encoder: M627A)

Not recommended for new installations. Use style 1 or style 2 instead. For unidirectional, reluctance type applications. The K661 output voltage does not reverse and drops to zero at low RPMs. (Depending on

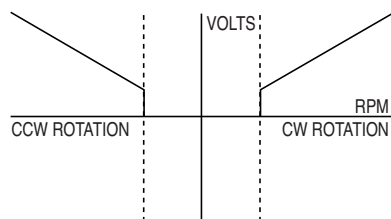

cable length, this occurs at 30 to 50 RPM.) Two wire interconnection to K661.

For further information on which encoder to specify, consult Avtron (216) 642-1230.

#### NOTE

**When using a style 2 or a style 3 encoder, the output polarity can be reversed by a jumper on the K661.**

**When using a style 1, the output polarity may be reversed by reversing the ØA – ØB inputs.**

The K661 provides a full scale output of  $\pm 300$  VDC at up to 3 milliamperes of current. The unit can be programmed for 50, 100, or 200 volts per 1000 RPM by a jumper on TB1. The K661 provides a high conversion speed for a very stable linear output. Because only the encoder or pulse generator is mounted directly to the machine, the K661 is to be located in a separate equipment enclosure, isolated from vibration and other adverse environmental effects. This will provide reliable operation and extended service life.

### INSTALLATION

Install the associated rotary pulse generator in accordance with the Encoder Installation Instructions and specific instructions for the encoder used.

The K661 should be mounted in an equipment enclosure. When mounting on a vertical panel, position the K661 mounting face with the longer dimension vertical to minimize tension loading on the upper mounting hardware.

Do not mount K661 near sources of large electrical noise such as contactors, motor starters, etc. The K661 should be located in an environment where the ambient temperature does not exceed 140°F.

### REPAIR OR REPLACEMENT

To minimize costly downtime, it is recommended that a spare K661 be kept on hand. In the event of a suspected malfunction, the unit can be quickly removed and the spare installed with no setup changes required.

If the unit is to be sent back to the factory, it is suggested that the user notify Avtron's Field Service Department and supply them with the model and part number of the unit. A brief description of the suspected fault is also helpful.

### PREPARATION FOR USE

#### STEP 1: GAIN PROGRAMMING

#### CAUTION

**Always confirm that a jumper exists in one of these configurations before placing the unit into operation.**

Select proper jumper on TB1 as shown to achieve 50, 100, or 200 V/1000 RPM.



#### NOTE

**Unit is shipped with jumper set for 200 V/1000 RPM.**

## STEP 2: INPUT CONNECTIONS

Connect the encoder or pulse generator to the input of the K661 per the appropriate style interconnection diagram below. Refer to the instruction sheet for the specific encoder to get the correct connections for that model and output connector option. Note: K661 TB1 terminal numbering does not reflect the physical locations of terminal points.

**STYLE 1:** Encoders with two phase (A,B) type outputs.

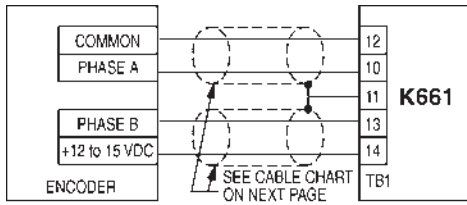

Typical for encoders such as Avtron Model M485.

The K661 input is single ended. When using encoders with differential outputs such as Avtron Models M3, M193B, M285, M4, M485, and M685 follow the examples for single ended applications and leave the complementary outputs un-terminated. The above connections will result in positive output of the K661 for clockwise rotation as viewed from the anti-drive end of the encoder. Counter clockwise rotation will result in negative output. To reverse polarity, reverse phase A and phase B connections at TB1 (K661).

**STYLE 2:** Encoders with single phase zero speed outputs.

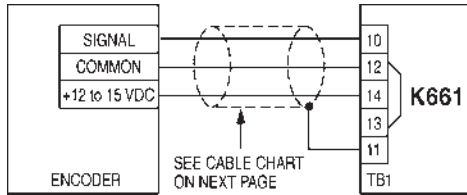

Typical for Avtron Encoders.

The above connections will result in positive output of the K661 for both clockwise and counter clockwise rotation of the encoder. For negative output omit the jumper between K661 terminals 12 and 13 on TB1.

**STYLE 3:** Encoders with single phase reluctance type outputs.

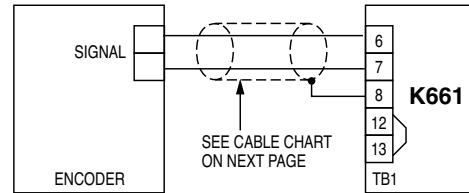

Typical for encoders such as Avtron Model M627A and M628A.

The above connections will result in positive output of the K661 for both clockwise and counter clockwise rotation of the encoder. For negative output omit the jumper between K661 terminals 12 and 13 on TB1.

## STEP 3: OUTPUT CONNECTIONS

Output COMMON is isolated from earth ground.

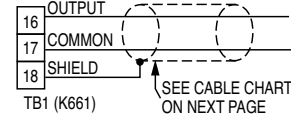

## STEP 4: AC POWER CONNECTIONS

\*For 230 VAC input power, remove cover and connect jumpers as

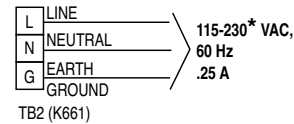

shown on printed circuit board silkscreen.

## SPECIFICATIONS

All specifications are determined using a 240 PPR Encoder. For specifications when using a different PPR Encoder, consult the factory.

### INPUT

1. Power .....115 VAC  $\pm 15\%$ , approx. 0.25 A
2. Transformer isolated reluctance input TB1 (6) and (7)
  - a. Impedance .....600 ohms  $\pm 20\%$  from 100 to 10,000Hz; 40 ohms DC resistance.
  - b. Input Speed .....0 to 3000 RPM at 50 V/1000 RPM  
0 to 3000 RPM at 100 V/1000 RPM  
0 to 1500 RPM at 200 V/1000 RPM
  - c. Input Waveform .....0.5 to 5.0 V Sine Wave
3. Zero Speed Input
  - a. Impedance .....10 K ohms
  - b. Input Speed .....Same as above
  - c. Input Waveform .....5.0 to 15.0 volts square wave.
  - d. Encoder Power .....13.5 VDC @ 100 mA

### SIGNAL OUTPUT

1. Full Scale Voltage .....a) (Bidirectional) 300  $\pm 3$  VDC  
b) (Unidirectional) 300  $\pm 3$  VDC  
0 VDC at 0 Hz.
2. Programmable Output Gains  
.....50, 100, and 200 volts per 1000 RPM  
of encoder with 240 pulses per revolution (PPR).

3. Signal Output Polarity .....a) (Bidirectional): Determined by phase order from encoder; i.e.,  $\text{O}A$  leads  $\text{O}B$  for (+) output.  
.....b) (Unidirectional): Determined by jumper on TB1; i.e., jumper on terminals (12) and (13) of TB1 is (+) output. Remove jumper for (-) output.

### OUTPUT LINEARITY ....Maximum 0.002% of full scale.

1. Temperature Drift .....Maximum  $\pm 0.05\%$  of full scale from 32 to 140°F
2. Stability .....Maximum  $\pm 0.02\%$  of full scale over 30 days

**OUTPUT RIPPLE** .....Volts peak-to-peak depends upon the input speed. Open loop ripple at 100 V/1000 RPM is .9 VRMS at 25 RPM, 0.15 VRMS at 250 RPM, and 0.1 VRMS at 2500 RPM. This is significantly lower than conventional brush type generators above 25 RPM. Below 25 RPM the ripple amplitude is comparable to DC generators but has less effect on speed because the ripple frequently is higher.

**RISE TIME**.....0.01 seconds for a step change in frequency. (Time to reach 90% of final value.)

**LOAD IMPEDANCE**.....100 K ohms (minimum) for full scale 300 VDC output.

**LOAD CURRENT** .....3mA output current maximum.

# K661

Model K661 Replacement Parts List – Serial Number 4086 and up.

Schematic Reference	Part No.	Description	Qty. Unit
	A12718	P.C. Board Assembly, Rev. BJ	1
R33	123013	Resistor, 100 Ohms, 1/2 W, 1%	1
R31, 32	135022	Resistor, 15 K, .33 W, .01%	2
R30	110035	Resistor, 6.8 K, 1/2 W, 10%	1
R2, 3, 40, 42, 43, 45	110037	Resistor, 10 K, 1/2 W, 10%	6
R24, 28	110057	Resistor, 560 K, 1/2 W, 10%	2
R50	110015	Resistor, 150 Ohms, 1/2 W, 10%	1
R52, 53	110101	Resistor, 100 K, 1 W, 10%	2
R16, 18	134512	Resistor, 56 Ohms, 11 W, 5%	2
R17	134083	Resistor, 270 Ohms, 5 W, 5%	1
R49	110212	Resistor, 56 K, 2 W, 10%	1
R15	123039	Resistor, 15 K, 1/2 W, 1%	1
R13, 14	110130	Resistor, 330 Ohms, 1 W, 10%	2
R7, 8	135021	Resistor, 500 K, .33 W, .1%	2
R6	123023	Resistor, 681 Ohms, 1/2 W, 1%	1
R9, 41	123021	Resistor, 475 Ohms, 1/2 W, 1%	2
R10	110185	Resistor, 47 K, 2 W, 10%	1
IC3, 5	376803	Integrated Circuit (Motorola P/N MC14013BCPDS)	2
IC4	376805	Integrated Circuit (Motorola P/N MC14024BCPDS)	1
IC7	376825	Integrated Circuit (Fairchild P/N 4022DC)	1
IC2	376708	Integrated Circuit (Texas Instr. P/N TL074CN3)	1
IC1	376809	Integrated Circuit (Motorola P/N MC14016BCPDS)	1
C11	262110	Capacitor, .1 uF, 200 V	1
C21	241058	Capacitor, .22 uF, 50 V	1
C24, 27, 28, 29	241005	Capacitor, .01 uF, 100 V	4
C23	261106	Capacitor, .22 uF, 80 V	1
C9, 10, 13, 17, 18, 22	241056	Capacitor, .1 uF, 50 V	6
C7	265080	Capacitor, .0039 uF, 630 V	1
C6	265073	Capacitor, .047 uF, 600 V	1
C5, 15	245111	Capacitor, 330 PF, 1000 V	2

CABLE SELECTION CHART			
Number of Conductors	Wire Gauge	Maximum Run	Belden P/N or equivalent
2 (1-shielded pair)*	16	1,000 ft.	8719
3 (shielded)*	16	1,000 ft.	8618
4 (2-shielded pairs)	20	400 ft.	9402
3 (shielded)	20	400 ft.	8772
4 (2-shielded pairs)	22	250 ft.	8723
3 (shielded)	22	250 ft.	8771

Schematic Reference	Part No.	Description	Qty. Unit
C4	223004	Capacitor, 2200 uF, 25 VDC	1
C12	281214	Capacitor, 150 uF, 50 VDC	1
C1, 2, 25, 26	281061	Capacitor, 100 uF, 350 VDC	4
R25	110032	Resistor, 3.9 K, 1/2 W, 10%	1
R37	134155	Resistor, 560 Ohms, 5 W, 5%	1
R36	110054	Resistor, 330 K, 1/2 W, 10%	1
TB2	364684	Terminal Block, 3-Pin (Reed Devices P/N 6PCR-3)	1
TB1	364688	Terminal Block, 18-Pin (Reed Devices P/N 6PCR-18)	1
T2	A14525	Transformer	1
T1	A12912	Transformer	1
F1	324066	Fuse, 1 A, 250 V	1
IC8	A31789	PC Board, Oscillator 5.12 MHZ	1
CR10, 11, 17, 18, 20, 21, 22	354397	Semiconductor (1N457A)	7
CR8, 9, 12	354499	Semiconductor (1N4735A)	3
CR7, 13-16	354419	Semiconductor (1N4154)	5
CR4	354489	Semiconductor (1N4099)	1
CR1, 2, 5, 6, 19, 23, 24	354301	Semiconductor (1N4249)	7
U1	373972	Transistor (4N35)	1
Q4	373625	Transistor (JANTX2N2219A)	1
Q3	373982	Transistor (JANTX2N2905A)	1
Q1, 2	373568	Transistor (Motorola P/N MJ12002)	2
IC6	376665	Integrated Circuit (National Semiconductor P/N LM399H)	1
	444031	Heat Dissipator (T03) (Aavid Engr. Co. P/N EH-5759B)	2
	444019	Heat Dissipator (T05) (Aavid Engr. Co. P/N 5783B)	1
	358557	Pad Transistor (Thermalloy P/N 7717-159N)	2
C3	221203	Capacitor, 470 uF, 16 V	1
C8	221208	Capacitor, 470 uF, 25 V	1
C16	245108	Capacitor, .001 uF, 1000 V	1
T3	A12913	Transformer	1
R34		Resistor (Value to be determined at test)	1
R20	110241	Resistor, 1 Megohms, 2 W, 10%	1
R46, 47	110041	Resistor, 22 K, 1/2 W, 10%	2
R5, 11, 12, 19, 29, 38, 44, 48	110033	Resistor, 4.7 K, 1/2 W, 10%	8
R39	110021	Resistor, 470 Ohms, 1/2 W, 10%	1
	C14273	Schematic	ref.
C30	235204	Capacitor, 100 PF, 500 V	1

**NOTE:** Avtron standard warranty applies. Copies available upon request. Specifications subject to change without notice.

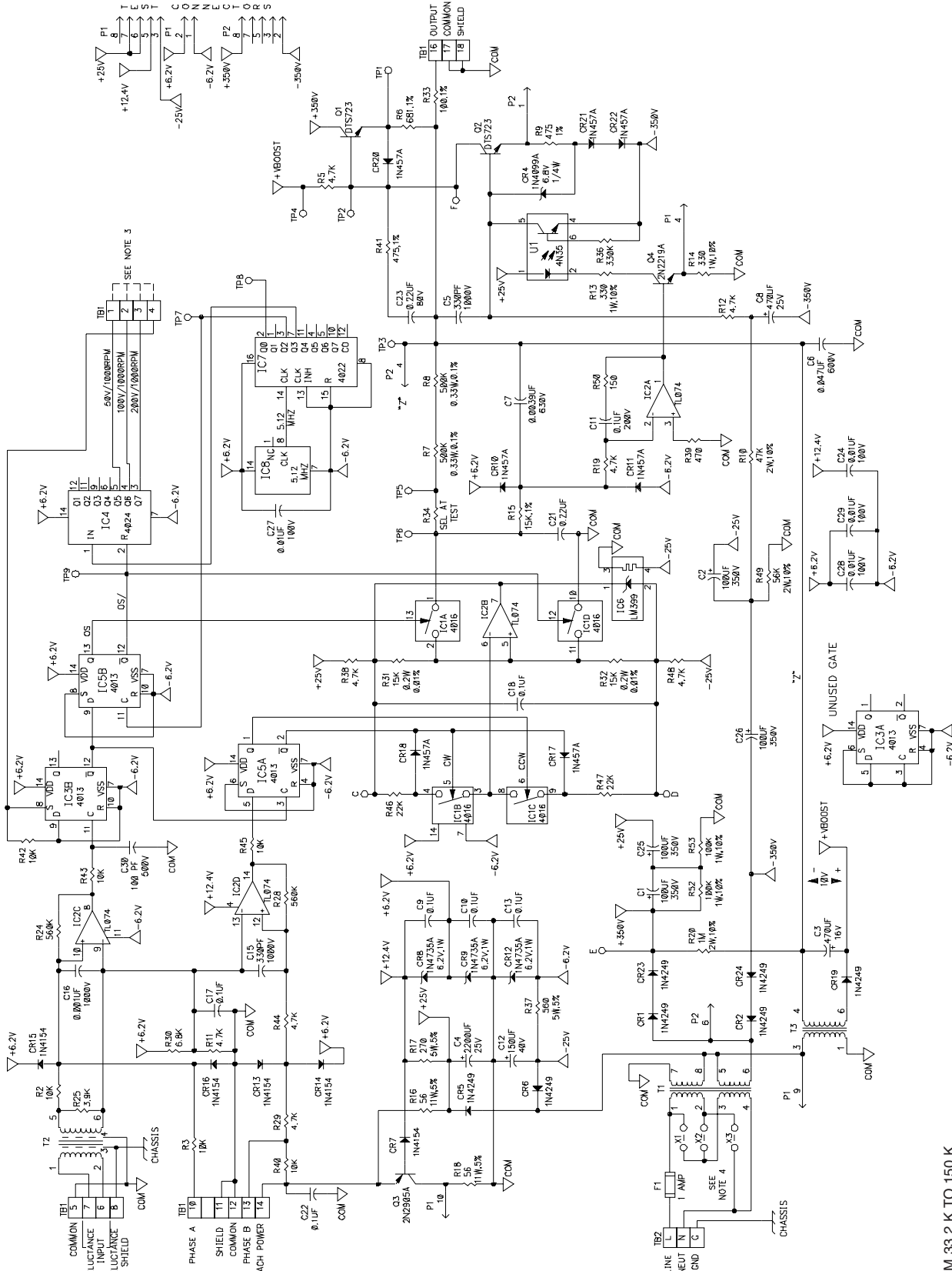

- 5 - R34 SELECT FROM 33.2 K TO 150 K
- 4 - USE X1 AND X3 FOR 115 VAC OPERATION;  
USE X2 ONLY FOR 230 VAC.
- 3 - JUMPER TB1-4 TO TB1-1, -2, OR -3 TO ACHIEVE  
DESIRED GAIN.
- 2 - CAPACITOR VALUES ARE IN MICROFARADS AND ARE 50 V
- 1 - RESISTOR VALUES ARE IN OHMS AND ARE 1/2 W, 10%

NOTES: UNLESS OTHERWISE SPECIFIED



AVTRON MANUFACTURING, INC.

8901 E. PLEASANT VALLEY RD., INDEPENDENCE, OH 44131, U.S.A. • (1) 216-642-1230 • FAX (1) 216-642-6037 • www.avtroncoders.com

REV. 11-20-07