



8901 E. PLEASANT VALLEY ROAD
 INDEPENDENCE, OHIO 44131-5508
TELEPHONE: (1) 216-642-1230 • **FAX:** (1) 216-642-6037
E-MAIL: tachs@avtron.com • **WEB:** www.avtronencoders.com

Encoder Instructions

AV25

SOLID SHAFT 1/4" - 10mm

DESCRIPTION

The Avtron Model AV25 Encoder is a light mill duty speed and position transducer (also known as tachometer or rotary pulse generator). When coupled to a motor or machine, its output is directly proportional to shaft position (pulse count) or speed (pulse rate).

Mechanically the AV25 mounts using industry standard 2.650" square flanges, as well as servo mount 2.500" or 2.625" round flanges. The AV25 can also be mounted using an optional industry standard face mount bolt pattern.

The AV25 encoder offers 2Ø outputs (A,B) 90° apart for direction sensing. Optional complements (Ā,Ḃ) and marker pulse and complement (Z,Z̄) are available; see channel options.

DRIVE INSTALLATION INSTRUCTIONS

The AV25 may be driven via a contact/friction wheel provided the axial spring force is modest, less than 25% of the 100 lb maximum radial load, or (preferably) the AV25 can be coupled to the load. The following means of coupling are acceptable when properly installed: Direct Coupling, Timing Belt/Pulleys.

With a direct drive, use a flexible, insulated disc coupling and align the shafts as accurately as possible. The encoder should not be subjected to any axial thrust. Overhung loads should also be minimized. Installations using timing belts/pulleys should have just enough belt tension to eliminate belt sag. Excessive tension will shorten belt and bearing service life. If a rubber slinger disc is used, position it on the shaft so it will rotate freely.

CAUTION

Do not force or drive the coupling onto the shaft or damage to the bearings may result. The coupling should slide easily on the shaft. Remove nicks and

Equipment Needed for Installation		
Provided	Optional	Not Provided
AV25 Encoder	Mating MS Cable Connector	AV25 Face Mounting Screws (see table below and drawing on last page for sizes) Thread Locker (Loctite 242 recommended) Anti-Seize Adapter Flange Shaft Coupling (Insulated Style recommended) Dial Indicator Gauge

burrs if necessary. Consider driving shaft endplay when positioning coupling.

For more details on alignment specifications, measurement techniques, and special considerations in specifying and installing drive components, refer to separate installation instructions in the Avtron ENCODER HANDBOOK.

FACE and FLANGE MOUNTING INSTRUCTIONS

- 1) Apply anti-seize compound to inner circumference of coupling (both motor and encoder side).
- 2) Loosen set screws in coupling and apply thread locker to set screws.
- 3) Place coupling on motor/load shaft, inserting to depth per manufacturer's instructions.
- 4) Attach coupling to motor/load shaft using set screws per manufacturer's instructions.
- 5) Slide encoder shaft into other side of coupling. **DO NOT**

AV25 PART NUMBERS AND AVAILABLE OPTIONS

Mount	PPR*	Line Driver	Shaft Size	Connector Options	Wiring	Mounting Style	Face/Bolt Pattern	Seals	Channels	Special Features
AV25	A- 1 C- 25 F- 60 G- 100 H- 120 K- 200 L- 240 M- 250 N- 256 P- 300 E- 360 Q- 500 R- 512 S- 600 T- 625	U- 720 V- 900 W- 1000 Y- 1024 Z- 1200 1- 1250 2- 1440 3- 2000 4- 2048 5- 2500 6- 2540 7- 3600 D- 4096 9- 5000 0- Special	1- 5-28V (7272) 2- 5-28V, open collector (7273) 3- 5-15V (4469) 4- 5-28V in, 5V out (7272)	0- Non-std. With Flat A- 0.25" B- 0.375" C- 10mm Without Flat N- 0.25" P- 0.375" R- 10mm	W- 18" cable (pigtail) A- Side E- End	1- Sq. Flange 2.625" w/ 1.25" male pilot 2- Rnd. Flange 2.5" w/ 1.25" male pilot 3- Rnd. Flange 2.62" no pilot	X- None 1- 3x 10-32 @ 1.875" 2- 4x 4-40 @ 1.272" [^] 3- 4x 4-40 @ 2" 4- 3x 6-32 @ 2"	A- Shaft Sealed** B- Bearing Sealed X- None^^	With Comp. A- A,Ā,B,B̄ Z,Z̄ *** B- A,Ā,B,B̄ D- A,Ā Without Comp. E- A, B, Z F- A, B	000- None 00W- Connector on 18" cable: Use w/ Option "T"- "U" 9xx- Specify cable length xx=feet (use w/ Option "W")

* up to 16,384 PPR available
 ** recommended, N/A with Mounting Styles "3".
 *** N/A with MS 6 or 7 Pin Connector.
 ^ Only available with Mounting Style "3"
 ^^ not recommended for industrial applications

Connector Options			
Mounted on Encoder			Mounted on 18" cable (00W)
10 Pin MS	6 Pin MS	7 Pin MS	8 Pin M12
A- w/o plug (std. phasing)	E- w/o plug (std. phasing)	J- w/o plug (std. phasing)	T- w/o plug (Turck Pinout)
B- w/o plug (reverse phasing)	F- w/o plug (reverse phasing)	K- w/o plug (reverse phasing)	U- w/o plug (US Pinout)
C- w/ plug (std. phasing)	G- w/ plug (std. phasing)	M- w/ plug (std. phasing)	
D- w/ plug (reverse phasing)	H- w/ plug (reverse phasing)	N- w/ plug (reverse phasing)	

FORCE.

- 6) Ensure face on mounting flange matches and aligns with encoder face precisely.
- 7) Apply thread locker to face mounting screws or flange mounting bolts.
- 8) Align bolt holes of encoder and flange, thread in screws.
- 9) Tighten set screws on encoder side of coupling.

2) Exchange wires on cable, either at encoder cable end, or at speed controller end (but not both):

- a.) **Single Ended 2 Phase Wiring** (see wiring diagram)
Exchange A and B at the user end of the wires.
- b.) **Differential 2 Phase Wiring** (see wiring diagram)
Exchange **either** A with \bar{A} in the phase A pair **OR** B with \bar{B} in the phase B pair but **NOT** both.

WIRING INSTRUCTIONS

CAUTION

Be sure to remove power before wiring the AV25 Encoder.

Be sure to ground the cable shield: It can be connected to case ground at the encoder, or grounded at the receiving device, but should not be grounded on both ends.

If necessary, case ground can also be provided through a separate wire. (Not available for 6-pin connectors: options "E", "F", "G", "H"). Be certain not to ground the case ground wire if the encoder is already grounded by mechanical mounting or coupling.

For bidirectional operation of the AV25 Encoder, proper phasing of the two output channels is important. For models with A and B output channels. Phase A channel leads Phase B channel for clockwise shaft rotation as viewed from the rear of the encoder for the standard wiring options. Follow instructions under corrective installation as needed to reverse the direction of output or purchase AV25 with reverse phasing (options "B", "D", "F", "H", "K", "N").

CORRECTIVE ACTION FOR PHASE REVERSAL

- 1) Remove power.

3) Apply power.

4) Verify encoder feedback is correct, using hand rotation of shaft, or jog mode of the speed controller.

Interconnecting cables specified in the wire selection chart below are based on typical applications. Refer to the system drawing for specific cable requirements where applicable.

Physical properties of cable such as abrasion, temperature, tensile strength, solvents, etc., are dictated by the specific application. General electrical requirements are: stranded copper, 22 thru 16 gauge, each wire pair individually shielded with braid or foil with drain wire, 0.05 uF maximum total mutual or direct capacitance, outer sheath insulator. See Wire Selection Chart below for some suggested cables.

*Maximum cable length (and line driver selection) is limited by several factors: line driver protection, maximum RPM, PPR, output voltage and cable capacitance. The open collector driver (option 2) is much more heavily limited by output frequency on long cable runs, and is not recommended for new applications. Line driver option 3 permits the longest cable lengths but has the least built-in protection against short circuits. Line driver options 1, 2 and 4 have the most protection against external faults but have less line drive capacity. These factors may dictate maximum potential cable length.

SPECIFICATIONS

ELECTRICAL

- A. Operating Power (Vin)
 1. Volts..... See Line Driver Options
 2. Current 50mA, no load
- B. Output Format See Channel Options (A, \bar{A} , B, \bar{B} , Z, \bar{Z} available)
- C. Signal Type Incremental, Square Wave, 50% \pm 10% Duty Cycle
- D. Direction Sensing Phasing with respect to rotation as viewed from the back of the encoder (non-shaft side).
 - Connector options "A", "C", "E", "G", "J", "M", & "W": \emptyset A leads \emptyset B for CW rotation (Std. phasing).
 - Connector options "B", "D", "F", "H", "K", & "N": \emptyset A leads \emptyset B for CCW rotation (Reverse phasing).
- E. Transition Separation..... 15% minimum
- F. Frequency Range 0 to 125kHz.
- G. PPR 1 - 5000 standard (for other PPR needs up to 32,768 consult factory)
- H. Output..... See Line Driver Options

MECHANICAL

- A. Acceleration..... 6,000 RPM/Sec.
- B. Speed 6,000 RPM max. (for higher RPM needs, Consult Factory).
- C. Shaft Diameter 0.25" to 0.394" [6.35mm to 10mm]
- D. Shaft Loading up to 100 lbs. [045 kg] axial or radial
- E. Starting Torque @ 25C... 2.5oz in max. [0.01n-m] (1.0oz [0.007n-m] in w/o seals)
- F. Weight 0.95 lbs. [431g]

ENVIRONMENTAL

- A. Enclosure Rating NEMA 4, 13, IP65 (dust and water tight, not for immersion).

- B. Operating Temp. -40° to +100°C
- C. Humidity 98% Non-condensing
- D. Shock..... 50G, 11 ms Duration
- E. Vibration 5-2000Hz @ 20G

LINE DRIVER OPTIONS

		Output Options			
		1	2	3	4
Output Type		Differential Line Driver	Open Collector	High Current Differential Line Driver	Differential Line Driver, 5V fixed
Line Driver		7272	7273	4469	7272
Voltage Input (Vin)		5-28VDC	5-28VDC	5-15VDC	5-28VDC/5V Out
Protection	Reverse Voltage	Yes	Yes	Yes	Yes
	Transient	Yes	Yes	Yes	Yes
	Short Circuit	Yes	Yes	No	Yes
Maximum Cable length*		5V 1000 ft [300m] 12V 500 ft [150m] 24V 200 ft [60m]	see note*	1000 ft [300m]	200 ft [60m]

WIRING DIAGRAMS

LINE DRIVER (Output Option 1, 3, & 4) DIFFERENTIAL TWO PHASE WIRING APPLICATIONS

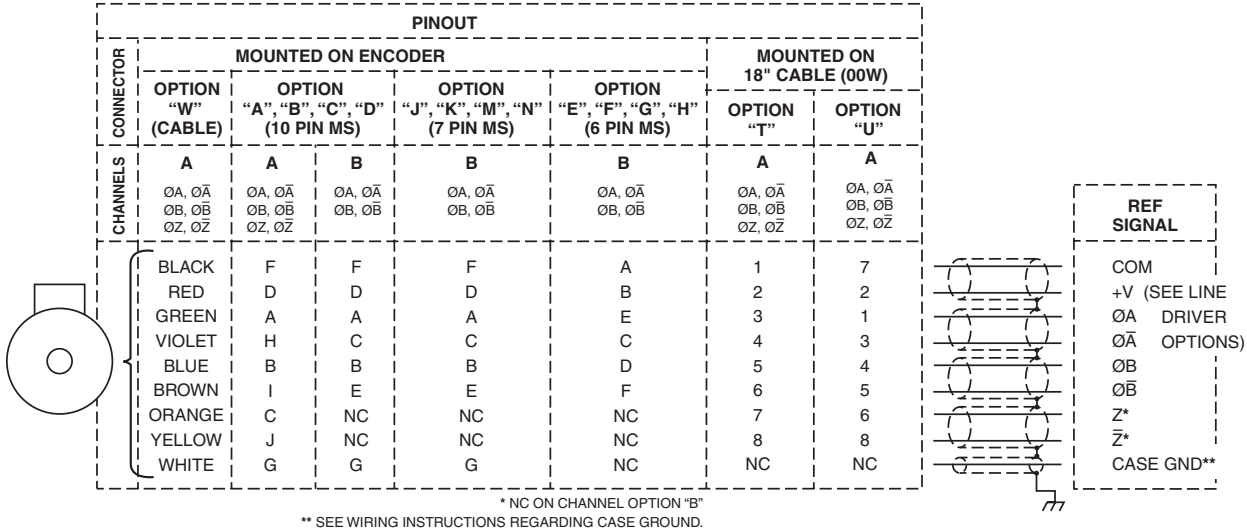

LINE DRIVER (Output Option 1-4) SINGLE ENDED TWO PHASE WIRING APPLICATIONS, WITH OR WITHOUT MARKER

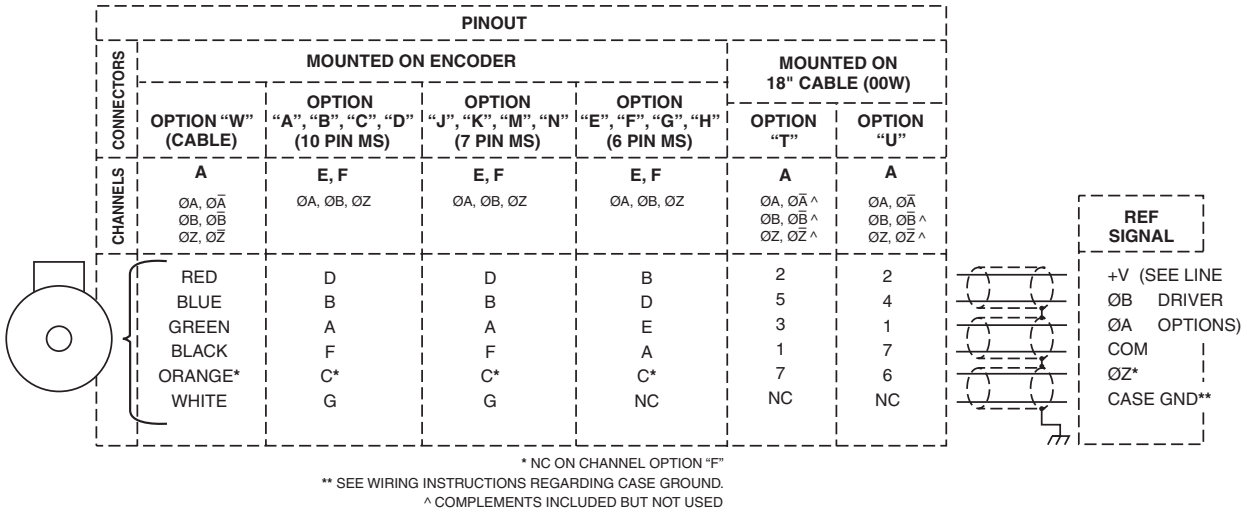

LINE DRIVER (Output Option 1-4) SINGLE ENDED SINGLE PHASE WIRING APPLICATIONS

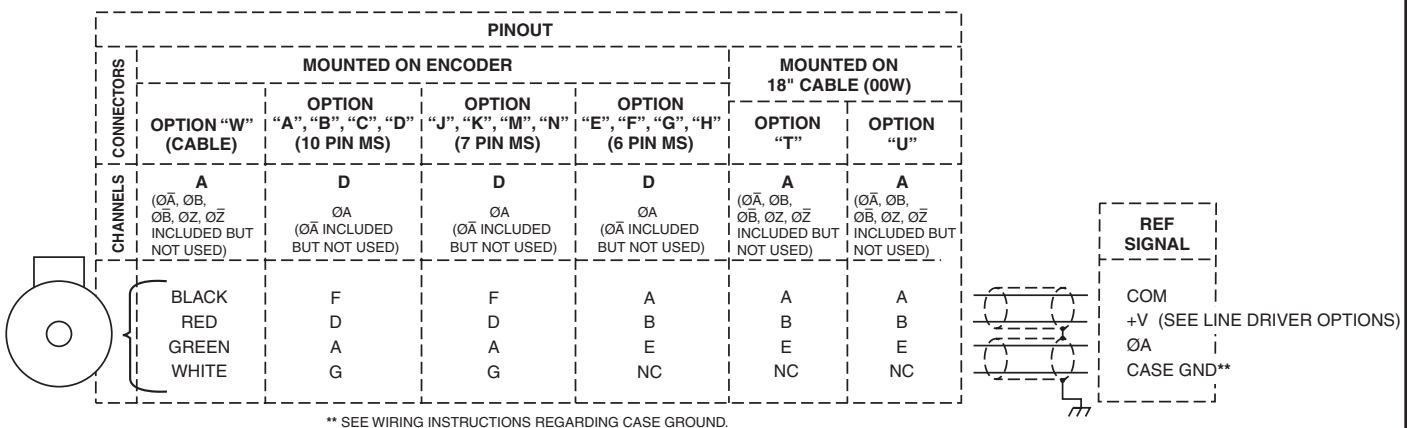

TYPICAL WIRE SELECTION CHART for 18 AWG, multiple pair, individually shielded

	BELDEN	ALPHA
2 PAIR	9368	6062C
3 PAIR	9369	6063C
4 PAIR	9388	6064C
6 PAIR	9389	6066C

Open Collector Line Driver Output Option 2 requires pull up resistors from each active output to a +V reference.

For Connector Option "W", unused connections must be insulated to prevent accidental contact.

* **NOTE:** Connecting Case Ground is optional, and is not recommended if the encoder is already grounded by mechanical means or coupling.

OUTLINE DRAWING

MOUNTING STYLE OPTION 1

SQUARE FLANGE (MALE PILOT)

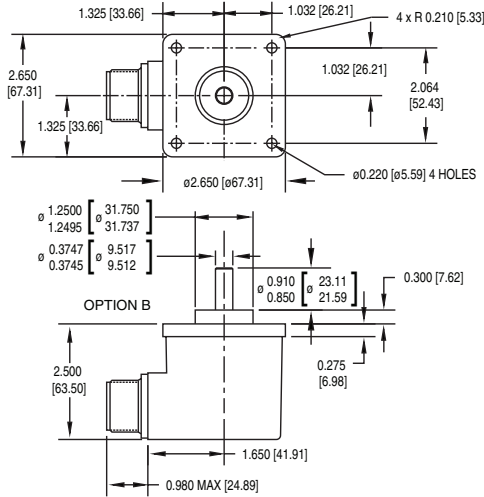

FACE / BOLT OPTIONS

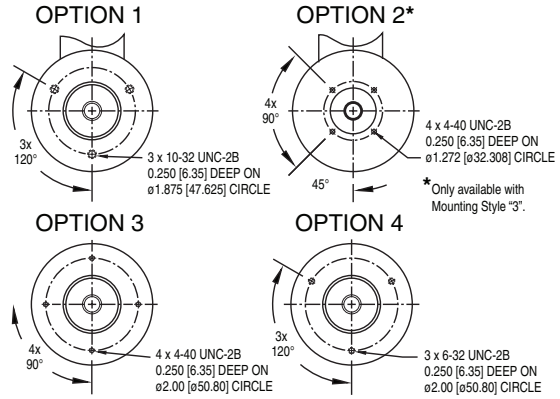

MOUNTING STYLE OPTION 2

ROUND FLANGE (ϕ 2.500 [63.50] SERVO MOUNT)

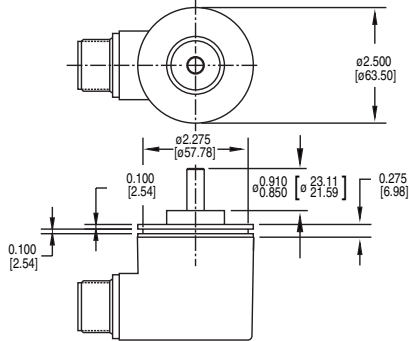

MOUNTING STYLE OPTION 3

ROUND FLANGE (ϕ 2.62 [66.68] SERVO MOUNT)

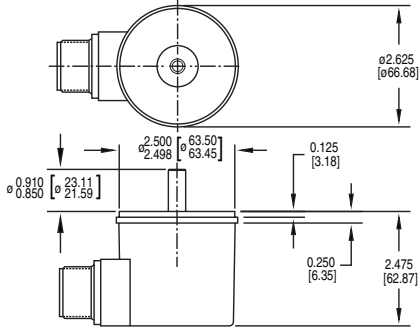

WIRING OPTIONS

CONNECTOR OPTION "W"
18" [457.2] CABLE (PIGTAIL)

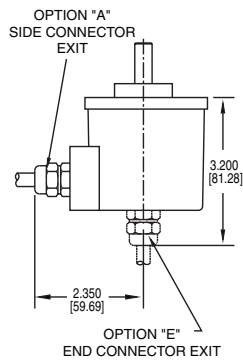

CONNECTOR OPTIONS:

"A", "B", "E", "F", "J", "K"
MS BOX CONNECTOR ONLY

CONNECTOR OPTIONS:

"C", "D", "G", "H", "M", "N"
MS CONNECTOR WITH MATING PLUG

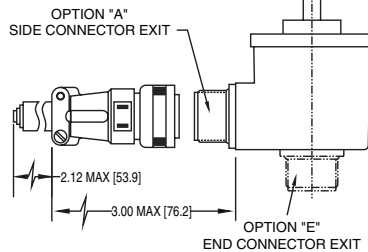

SHAFT OPTIONS

OPTIONS "A" "B" "C" WITH FLAT
(0.70 [17.8] LONG x 0.018 [0.46] DEEP)

OPTION "A" = SHAFT ϕ .2497/.2495 [6.342/6.337]
OPTION "B" = SHAFT ϕ .3747/.3745 [9.517/9.512]
OPTION "C" = SHAFT ϕ 10mm [.3942/.3935]

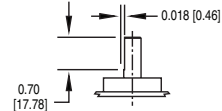

OPTIONS "N" "P" "R" NO FLAT

OPTION "N" = SHAFT ϕ .2497/.2495 [6.342/6.337]
OPTION "P" = SHAFT ϕ .3747/.3745 [9.517/9.512]
OPTION "R" = SHAFT ϕ 10mm [.3942/.3935]



- NOTES:
3. Dimensions are in inches [millimeters].
2. All dimensions are approximate.
1. Weight: 0.95 lbs [431 g]

Features and specifications subject to change without notice.
Avtron standard warranty applies. All dimensions are in inches [mm].